

1 PLAN
Scale: 1/2" = 1'-0"

WEIGHT:
LID = 1,760 LBS
BASE = 8,185 LBS

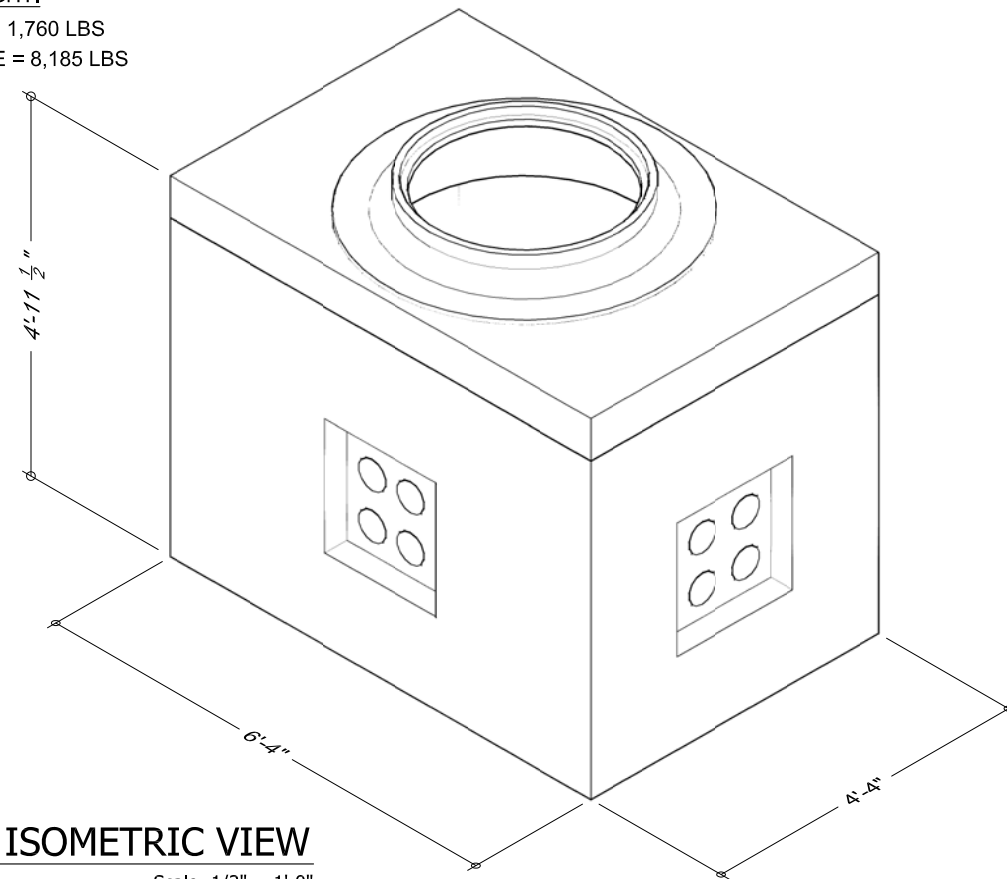

2 ISOMETRIC VIEW
Scale: 1/2" = 1'-0"

DESIGN NOTES

THE STRUCTURAL NOTES BELOW ARE FOR STANDARD VAULTS. WE CAN DESIGN VAULTS TO MEET OTHER SPECIFICATIONS.

- 1. CONCRETE: 28 DAY COMPRESSIVE STRENGTH $f_c = 6,500$ PSI
- 2. REBAR: ASTM A-615 GRADE 60
- 3. MESH: ASTM A-185 GRADE 65
- 4. DESIGN: AASHTO HS-25 TRUCK WHEEL.

ASTM C-857 "MINIMUM STRUCTURAL DESIGN LOADING FOR UNDERGROUND PRECAST CONCRETE UTILITY STRUCTURES."

ASTM C-858 "UNDERGROUND PRECAST UTILITY STRUCTURES"

30% IMPACT PER ASTM C-857 FOR LESS THAN 12" SOIL COVER

SOIL DENSITY 120 PCF

40 PCF E.F.P. LATERAL SOIL PRESSURE ABOVE WATER TABLE

80 PCF E.F.P. LATERAL SOIL PRESSURE BELOW WATER TABLE

TOP OF VAULT 10" BELOW FINISHED GRADE

WATERTABLE 5'-0" BELOW FINISHED GRADE

WE CAN PROVIDE DRAWINGS AND CALCULATIONS STAMPED BY A PROFESSIONAL ENGINEER

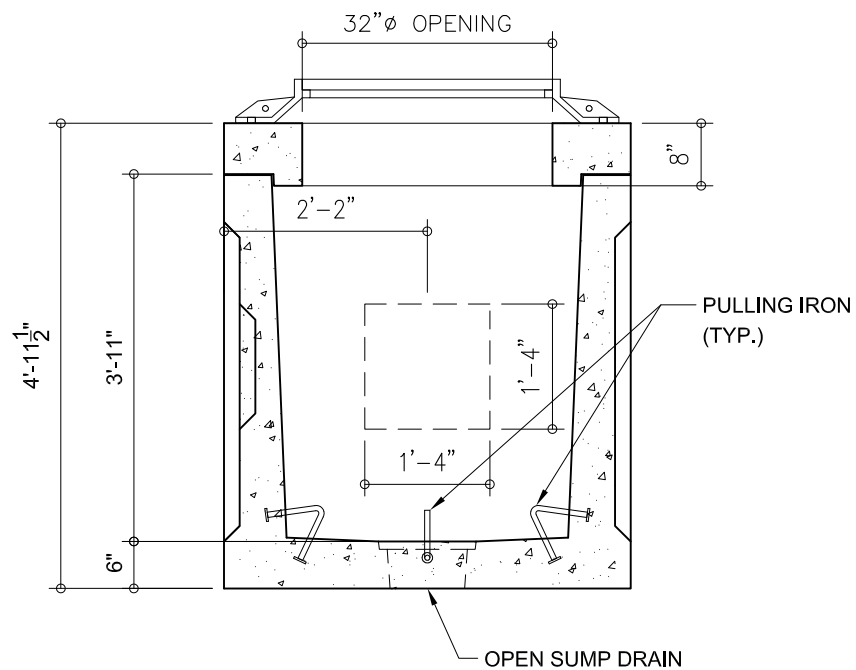

3 SECTION
Scale: 1/2" = 1'-0"

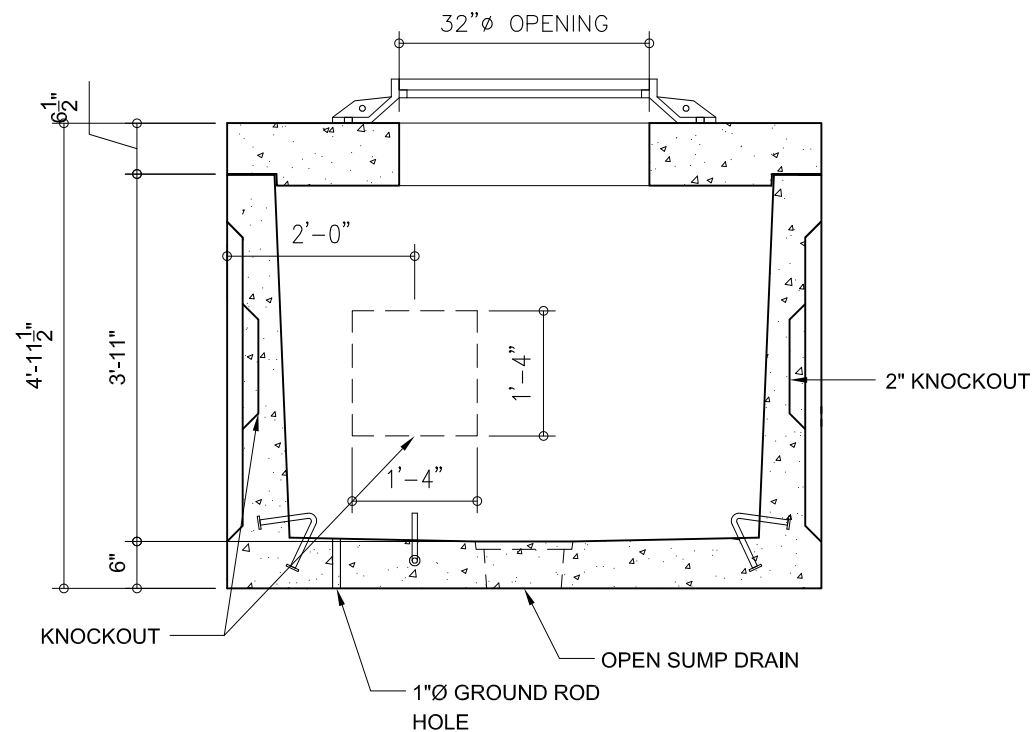

4 SECTION
Scale: 1/2" = 1'-0"

MANHOLE
3' W x 5' L x 3.75' D WITH
32"Ø OPENING IN LID

THIS IS THE PROPERTY OF ROCKY MOUNTAIN PRECAST. COPYING OF THIS DRAWING OR USING ITS CONTENTS WITHOUT PERMISSION FROM ROCKY MOUNTAIN PRECAST IS STRICTLY PROHIBITED. ECONOMIC ESPIONAGE ACT 1996 18 UCS 1831-39



PROJECT:	PROJECT NO:
ENGINEER:	COORDINATOR:
DRAWN BY:	DATE:
CHECKED BY:	DATE: