

**1**  
**PLAN**  
Scale: 1/2" = 1'-0"

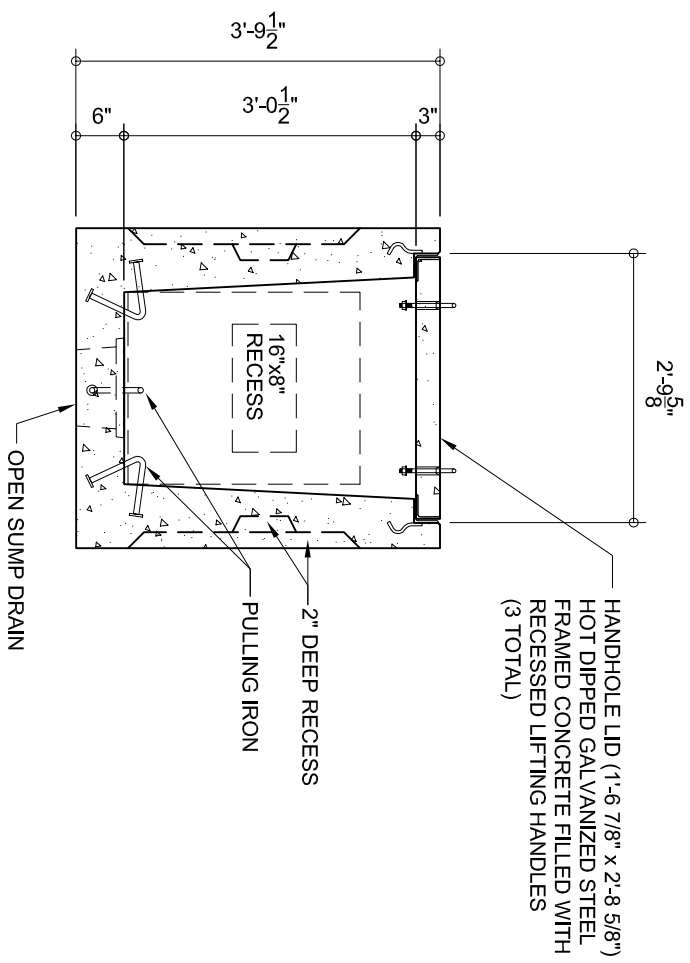

**3**  
**SECTION**  
Scale: 1/2" = 1'-0"

**WEIGHT:**  
LID = 161 LBS EACH  
BASE = 5,376 LBS

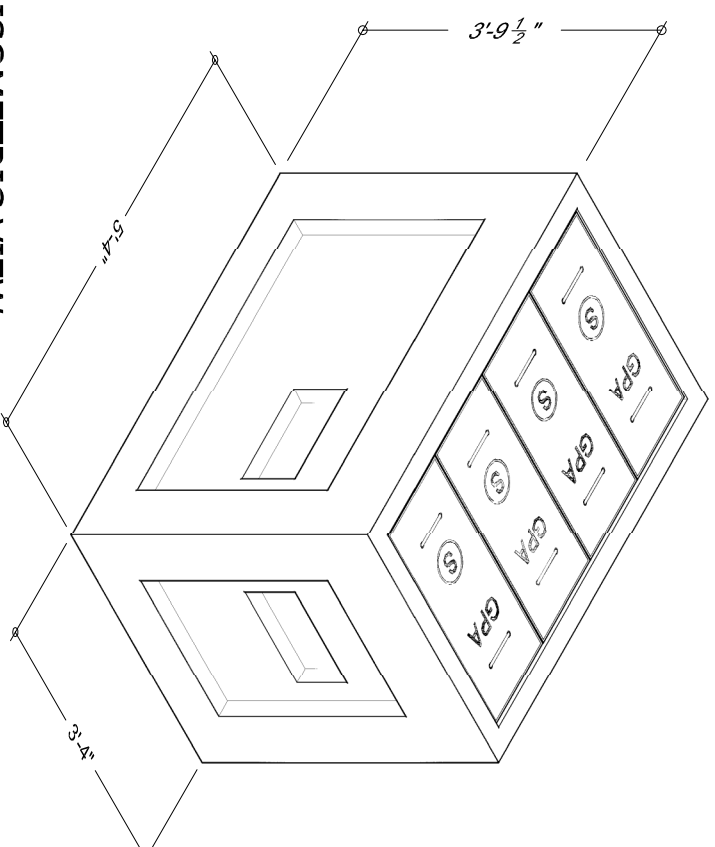

**2**  
**ISOMETRIC VIEW**  
Scale: 1/2" = 1'-0"

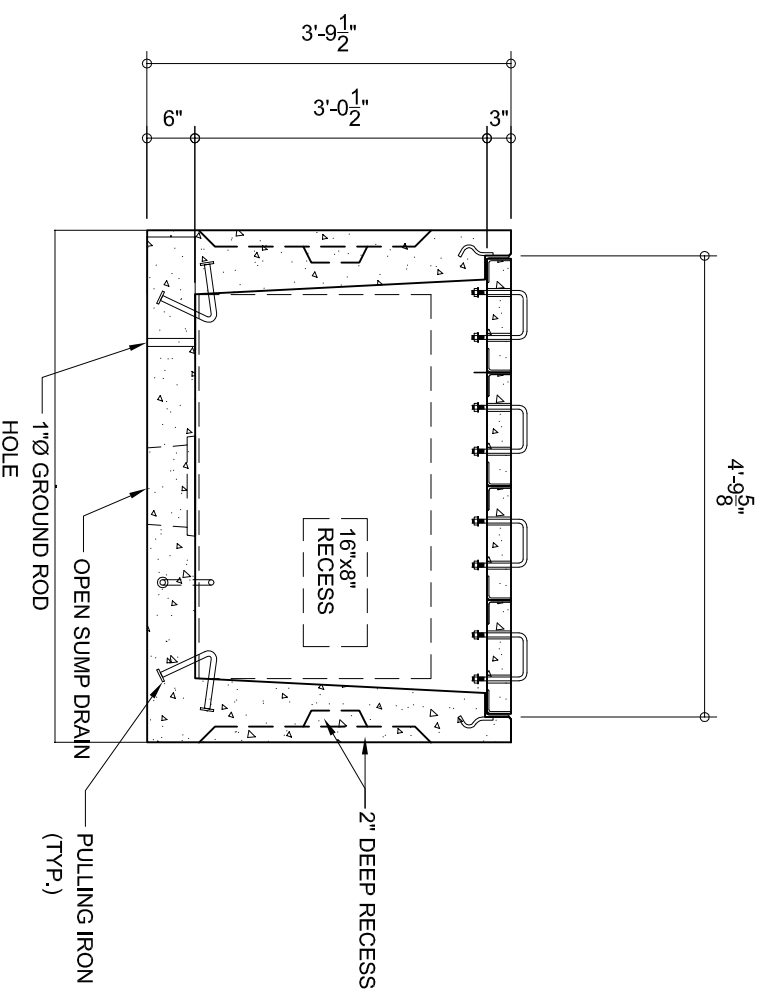

**4**  
**SECTION**  
Scale: 1/2" = 1'-0"

**DESIGN NOTES**

THE STRUCTURAL NOTES BELOW ARE FOR STANDARD VAULTS. WE CAN DESIGN VAULTS TO MEET OTHER SPECIFICATIONS.

1. CONCRETE: 28 DAY COMPRESSIVE STRENGTH  
 $f_c = 6,500$  PSI
2. REBAR: ASTM A-615 GRADE 60
3. MESH: ASTM A-185 GRADE 65
4. DESIGN: CONCENTRATED SERVICE LOAD OF 2,250 LBS ON SEGMENTED LIDS

ASTM C-857 "MINIMUM STRUCTURAL DESIGN LOADING FOR UNDERGROUND PRECAST CONCRETE UTILITY STRUCTURES."

ASTM C-858 "UNDERGROUND PRECAST UTILITY STRUCTURES"

SOIL DENSITY 120 PCF

40 PCF E.F.P. LATERAL SOIL PRESSURE ABOVE WATER TABLE

80 PCF E.F.P. LATERAL SOIL PRESSURE BELOW WATER TABLE

WE CAN PROVIDE DRAWINGS AND CALCULATIONS STAMPED BY A PROFESSIONAL ENGINEER

**HANDHOLE**  
2' W x 4' L x 3' D WITH SEGMENTED STEEL FRAMED CONCRETE LIDS

THIS IS THE PROPERTY OF ROCKY MOUNTAIN PRECAST. COPYING OF THIS DRAWING OR USING ITS CONTENTS WITHOUT PERMISSION FROM ROCKY MOUNTAIN PRECAST IS STRICTLY PROHIBITED. ECONOMIC ESPIONAGE ACT 1996 18 USC 1831-139



PROJECT NO.:  
ENGINEER: COORDINATOR:  
DRAWN BY: DATE:  
CHECKED BY: DATE: